

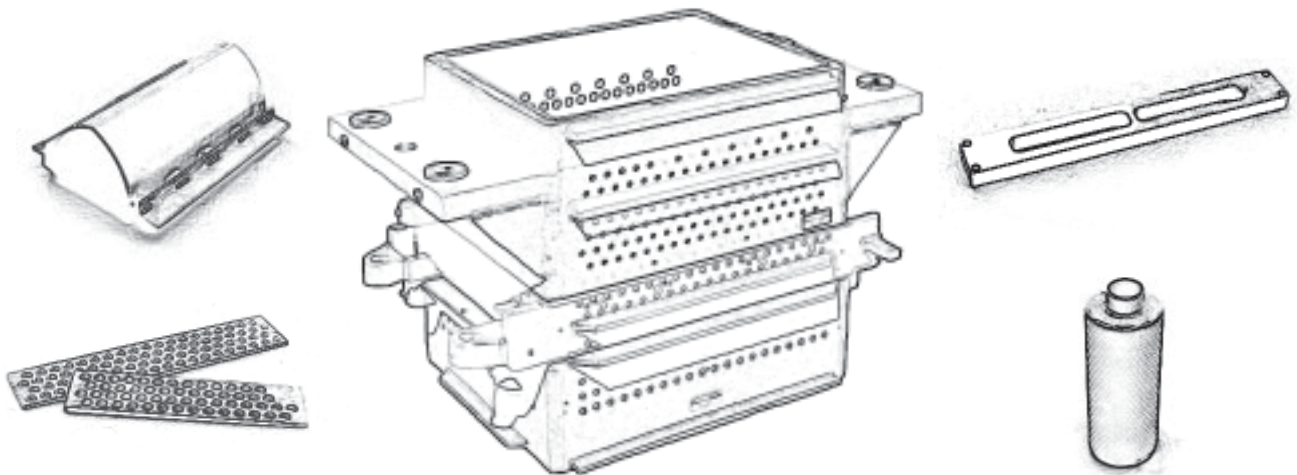

**Industrial
Automation
Service**

2008

**Beardsley & Piper Molding Machine
PARTS AND SERVICES CATALOGUE**



Industrial Automation Service, Inc.

4590 State Route 229 West Ashley, Ohio 43003

phone (740)-747-2222 fax (740)-747-2410

"Industrial Automation Service has been proud to serve the foundry industry for over thirty years. I feel one of the most important services we can provide our customers is honest advise. Our experience can be your solution."



Thomas Greer
 Thomas Greer
 PRESIDENT

What **IAS** can do for you...

FLASK REBUILDING

IAS has over 20 years of experience in restoring the B&P flasks to like-new functioning. Our unique, replaceable mating surfaces mechanically lock in the flask liner at its most critical edge. The result is an almost inseparable flask liner.

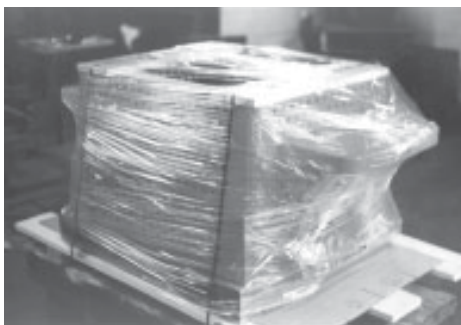

SPARE PARTS

IAS offers the most extensive line of B&P molding machine replacement parts than any other aftermarket supplier. Many of our parts are unique and reflect many years of incremental improvements over OEM designs.



CLAMP ASSEMBLY REBUILDING

Is a leaking clamp assembly costing you thousands in wasted hydraulic oil, bad sand, extra cleanup, and lost productivity? **IAS** offers two options for rebuilding your unit. Choose one based on your schedule flexibility.

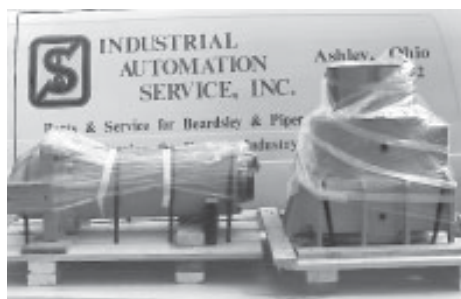

LOCATE THE PARTS YOU NEED THE FAST AND EASY WAY!

Pages 3 thru 11 will show you how

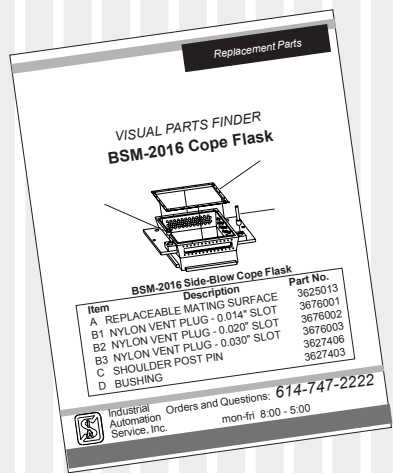

The *Visual Parts Finder* pages make it easier to locate part numbers, create spare parts lists, and identify components you may already have in stock. Each flask and squeeze plate for the BSM 2016 and 2620 machine is clearly drawn and labeled.



PLACING ORDERS

Regular business hours are 8:00am-5:00pm (EST) weekdays. To place orders, call:

Orders **1-(740)-747-2222**

Fax **1-(740)-747-2410**

Phone and fax orders accepted as well as written purchase orders, at your convenience. For remanufacturing services and orders over \$1,000.00, a written purchase order is required. A phone call is recommended to arrange for delivery date and freight preference. **IAS** is always glad to provide written quotations upon request.

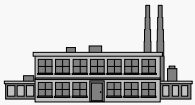

SHIPPING TO YOUR FOUNDRY

All freight is F.O.B. Ashley, Ohio 43003. Return of exchange equipment is to be via prepaid freight. Notify **IAS** in advance if you have an account or contract with a freight company. We will accommodate you whenever possible. Most small shipments are sent via ground UPS unless requested otherwise.

CREDIT TERMS

Normal credit extended to our customers requires full payment within 30 days of invoice date. A 0.5% discount can be taken if the invoice is paid in full within 10 days of the invoice date. New customers may be required to submit a credit application. Finance charges of 1.5% per month will accrue on unpaid balances beyond 30 days.



Industrial Automation Service, Inc.

4590 State Route 229 West
Ashley, Ohio 43003
(614)-747-2222 fax (614)-747-2410

Serving the foundry industry since 1975

CONTENTS

PAGE

- 3 Visual Parts Finder
for BSM-2016 Flasks
- 8 Visual Parts Finder
for BSM 2620 Flasks
- 12 Flask Replacement
Parts
- 15 Sand Magazine
Replacement Parts
- 18 Sand Gate
Replacement Parts
- 19 Flask Rebuilding
Services
- 22 Clamp Assembly
Rebuilding
- 24 Clamp Assembly
Parts
- 26 B&P Part Number
Cross Reference

Part Numbers and Prices

All part numbers listed are IAS part numbers, except where noted. To find Beardsley & Piper part numbers (where applicable), a handy cross reference is included in the back of this catalogue.

A price sheet insert is included with all catalogues. If the price list is missing from your catalogue or is out of date, call IAS and we will be glad to fax or mail you a new one.

VISUAL PARTS FINDER

BSM-2016 Cope Flask
TOP BLOW VERSION

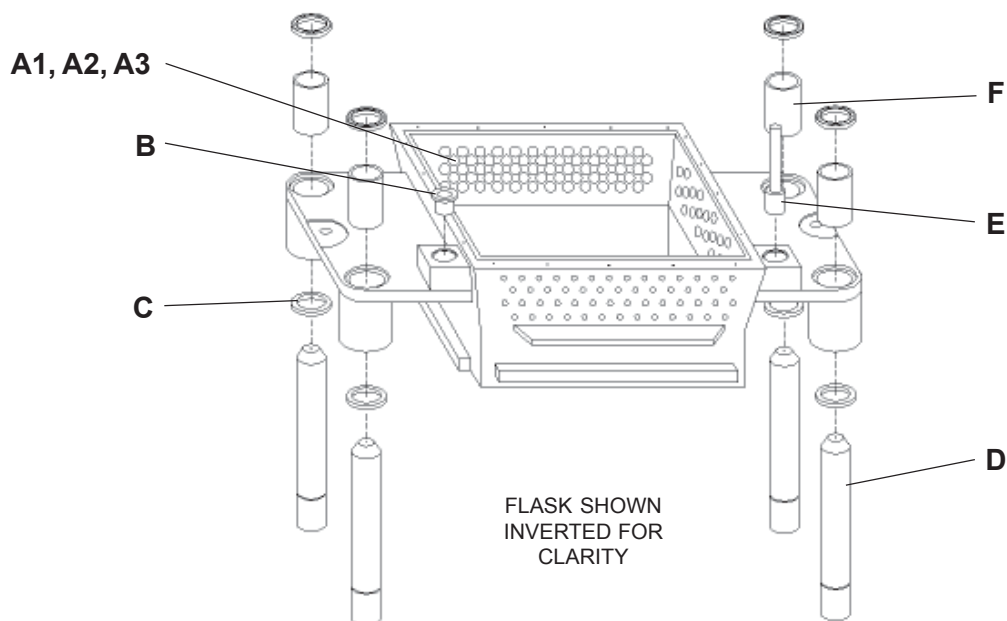

BSM-2016 Top Blow Version Cope Flask

Item	Description	Part No.
A1	BRASS VENT PLUG - 0.014" SLOT	3684001
A2	BRASS VENT PLUG - 0.020" SLOT	3684002
A3	BRASS VENT PLUG - 0.030" SLOT	3684003
B	BUSHING	3627403
C	BUSHING WIPER SEAL; PRESS-IN TYPE (8 REQ'D)	3050001
D	FLASK PIN (4 REQ'D)	3027402
E	SHOULDER POST PIN	3627406
F	BRONZE BUSHING SLEEVE (4 REQ'D)	3084002



**Industrial
Automation
Service, Inc.**

Orders and Product Info: (740)-747-2222

Hours: Mon.-Fri. 8:00 am-5:00 pm (EST). Fax orders anytime.

4590 State Route 229 West Ashley, Ohio 43003

VISUAL PARTS FINDER

BSM-2016 Cope Flask

SIDE-BLOW VERSION

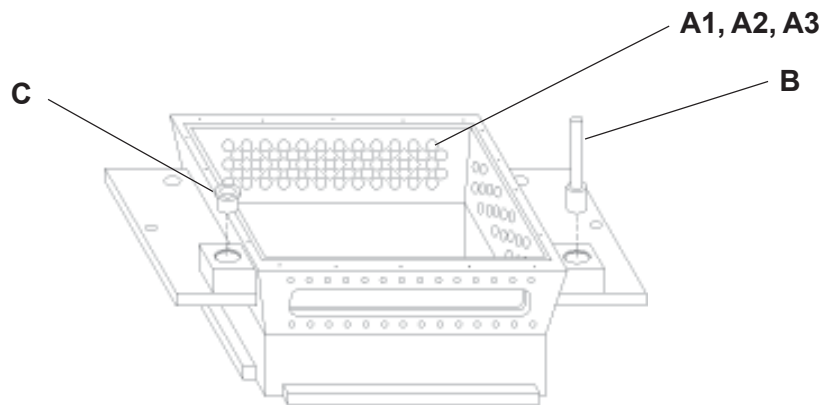

FLASK SHOWN
INVERTED FOR
CLARITY

BSM-2016 Side-Blow Cope Flask

Item	Description	Part No.
A1	BRASS VENT PLUG - 0.014" SLOT	3684001
A2	BRASS VENT PLUG - 0.020" SLOT	3684002
A3	BRASS VENT PLUG - 0.030" SLOT	3684003
B	SHOULDER POST PIN	3627406
C	BUSHING	3627403



Industrial
Automation
Service, Inc.

Orders and Product Info: (740)-747-2222

Hours: Mon.-Fri. 8:00 am-5:00 pm (EST). Fax orders anytime.

4590 State Route 229 West Ashley, Ohio 43003

VISUAL PARTS FINDER

BSM-2016 Cheek Flask

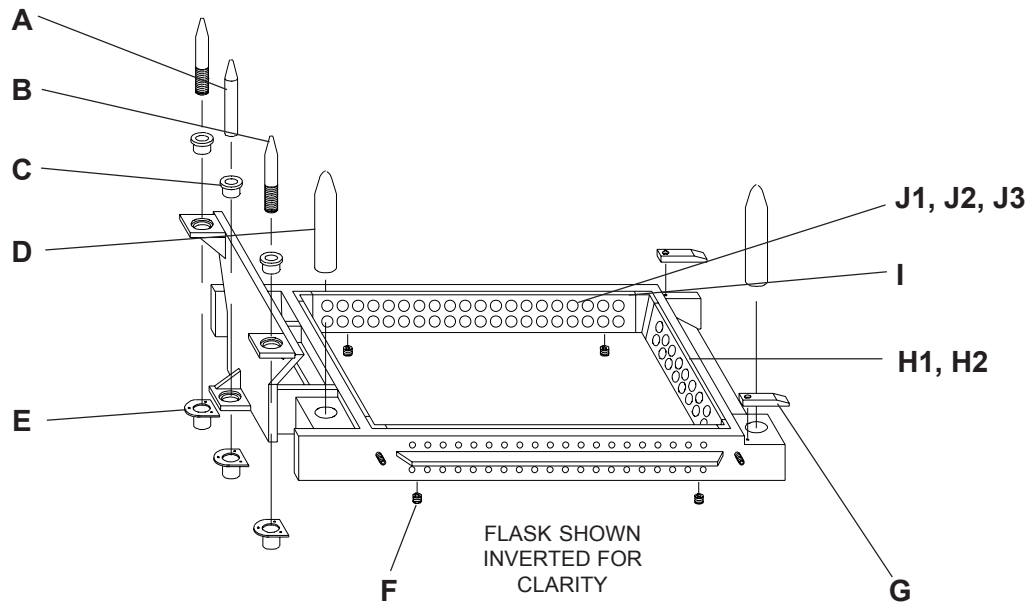

BSM-2016 Cheek Flask

Item	Description	Part No.
A	GUIDE PIN; UNTHREADED	3627401
B	GUIDE PIN; THREADED (2 REQ'D)	3627402
C	BUSHING (3 REQ'D)	3627405
D	FLASK PIN (2 REQ'D)	3627404
E	BUSHING SAND PROTECTOR CAP; URETHANE (3 REQ'D)	3636011
F	REPLACEABLE PATTERN MOUNTING INSERTS (4 REQ'D)	3425002
G	STRIKER BLOCK (2 REQ'D)	3225008
H1	CHEEK WEAR PLATE - 18 HOLE; w/o VENTS	3625010
H2	CHEEK WEAR PLATE - 20 HOLE; w/o VENTS	3625011
I	CHEEK WEAR PLATE - 32 HOLE; w/o VENTS	3625012
J1	BRASS VENT PLUG - 0.014" SLOT	3684001
J2	BRASS VENT PLUG - 0.020" SLOT	3684002
J3	BRASS VENT PLUG - 0.030" SLOT	3684003



**Industrial
Automation
Service, Inc.**

Orders and Product Info: (740)-747-2222

Hours: Mon.-Fri. 8:00 am-5:00 pm (EST). Fax orders anytime.

4590 State Route 229 West Ashley, Ohio 43003

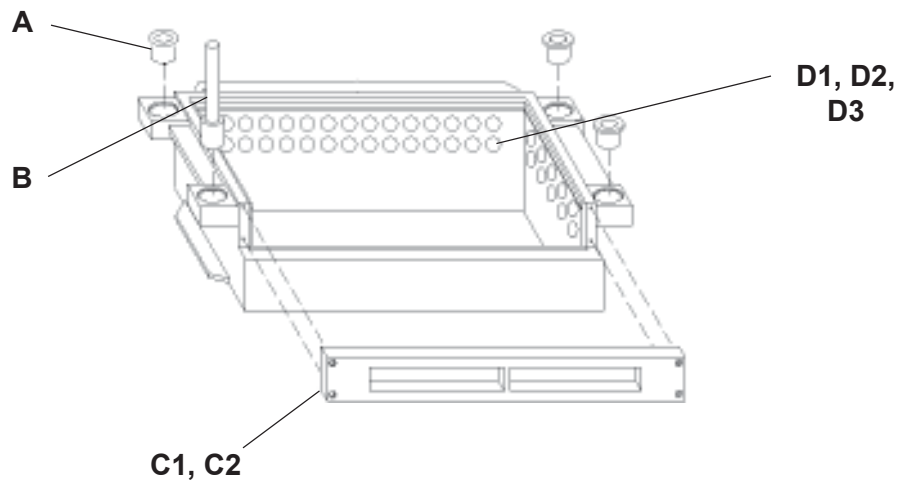
*VISUAL PARTS FINDER***BSM-2016 Drag Flask****BSM-2016 Drag Flask**

Item	Description	Part No.
A	BUSHING (3 REQ'D)	3627403
B	SHOULDER POST PIN	3627406
C1	REAR DRAG INSERT BAR; ALL-STEEL	3625001
C2	REAR DRAG INSERT BAR; ANGLED-SLOT	3625009
D1	BRASS VENT PLUG - 0.014" SLOT	3684001
D2	BRASS VENT PLUG - 0.020" SLOT	3684002
D3	BRASS VENT PLUG - 0.030" SLOT	3684003



**Industrial
Automation
Service, Inc.**

Orders and Product Info: (740)-747-2222

Hours: Mon.-Fri. 8:00 am-5:00 pm (EST). Fax orders anytime.

4590 State Route 229 West Ashley, Ohio 43003

VISUAL PARTS FINDER

BSM-2016 Squeeze Plates

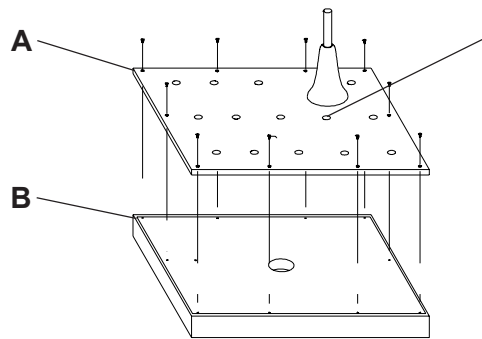

See the Price List for information on custom sprue plates

PLATE SHOWN INVERTED FOR CLARITY

BSM-2016 Top Squeeze Plate

Item	Description	Part No.
A	SPRUE MOUNTING PLATE; w/o HOLES	3627501
B	TOP SQUEEZE PLATE	3655002

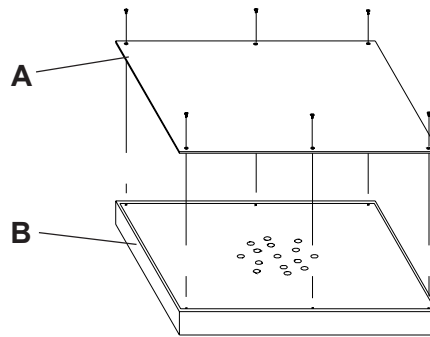

BSM-2016 Bottom Squeeze Plate

Item	Description	Part No.
A	TABLE WEAR COVER PLATE; UNMOUNTED/BLANK	3628003
B	BOTTOM SQUEEZE PLATE	3655001



**Industrial
Automation
Service, Inc.**

Orders and Product Info: (740)-747-2222

Hours: Mon.-Fri. 8:00 am-5:00 pm (EST). Fax orders anytime.

4590 State Route 229 West Ashley, Ohio 43003

VISUAL PARTS FINDER

BSM-2620 Cope Flask

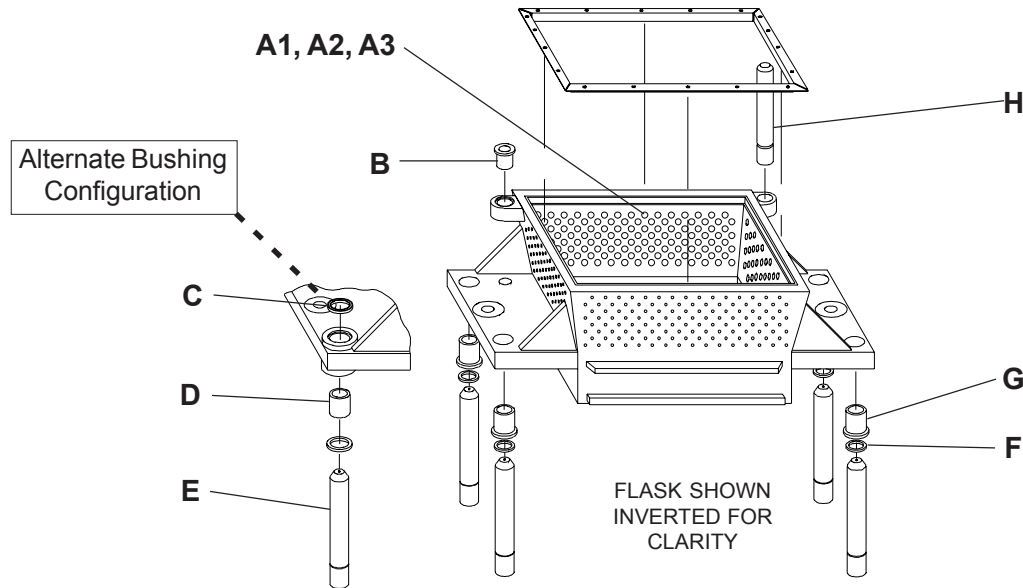

BSM-2620 Cope Flask

Item	Description	Part No.
A1	BRASS VENT PLUG - 0.014" SLOT	3684001
A2	BRASS VENT PLUG - 0.020" SLOT	3684002
A3	BRASS VENT PLUG - 0.030" SLOT	3684003
B	BUSHING	3027405
C	WIPER SEAL; PRESS-IN TYPE (8 REQ'D)	3050001
D	BRONZE BUSHING SLEEVE (4 REQ'D)	3084002
E	FLASK PIN (4 REQ'D)	3027402
F	WIPER SEAL (4 REQ'D)	3030001
G	BRONZE BUSHING (4 REQ'D)	3084001
H	FLASK PIN	3027401



Industrial
Automation
Service, Inc.

Orders and Product Info: (740)-747-2222

Hours: Mon.-Fri. 8:00 am-5:00 pm (EST). Fax orders anytime.

4590 State Route 229 West Ashley, Ohio 43003

VISUAL PARTS FINDER

BSM-2620 Cheek Flask

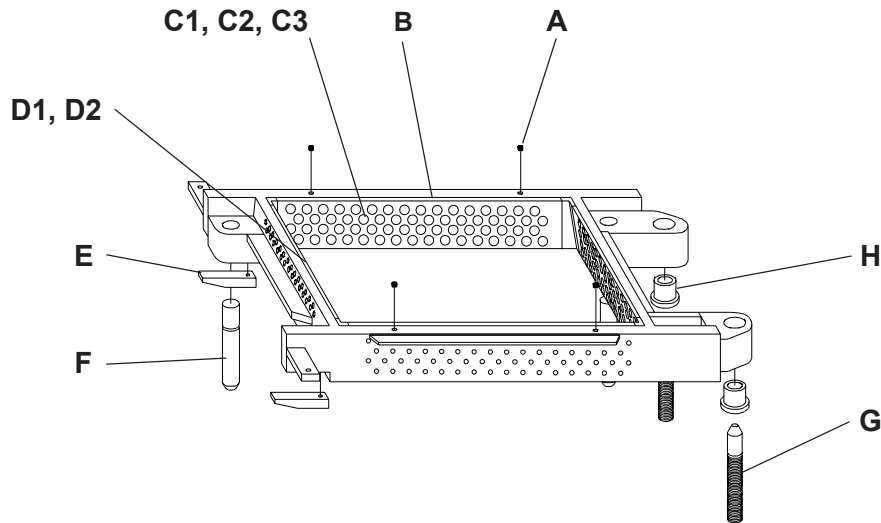

BSM-2620 Cheek Flask

Item	Description	Part No.
A	REPLACEABLE PATTERN MOUNTING INSERTS (4 REQ'D)	3425002
B	CHEEK WEAR PLATE - 78 HOLE (w/o VENTS)	3025007
C1	BRASS VENT PLUG - 0.014" SLOT	3684001
C2	BRASS VENT PLUG - 0.020" SLOT	3684002
C3	BRASS VENT PLUG - 0.030" SLOT	3684003
D1	CHEEK WEAR PLATE - 51 HOLE (w/o VENTS)	3025005
D2	CHEEK WEAR PLATE - 55 HOLE (w/o VENTS)	3025006
E	STRIKER BLOCK (2 REQ'D)	3325001
F	FLASK PIN (2 REQ'D)	3027403
G	FLASK PIN - THREADED (2 REQ'D)	3027404
H	BUSHING (2 REQ'D)	3627403



**Industrial
Automation
Service, Inc.**

Orders and Product Info: (740)-747-2222

Hours: Mon.-Fri. 8:00 am-5:00 pm (EST). Fax orders anytime.

4590 State Route 229 West Ashley, Ohio 43003

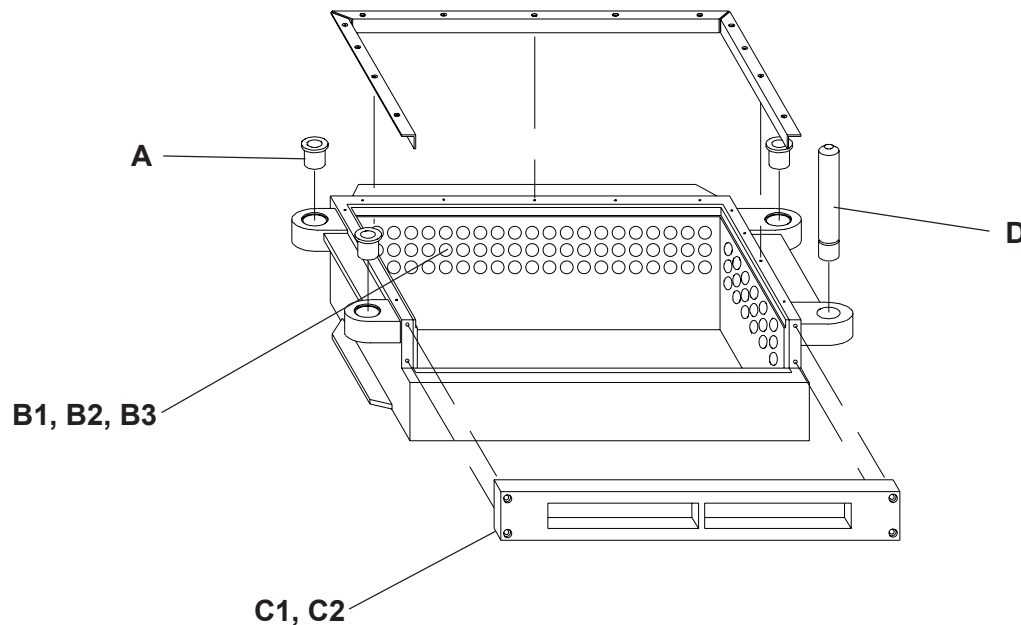
*VISUAL PARTS FINDER***BSM-2620 Drag Flask****BSM-2620 Drag Flask**

Item	Description	Part No.
A	BUSHING (3 REQ'D)	3027405
B1	BRASS VENT PLUG - 0.014" SLOT	3684001
B2	BRASS VENT PLUG - 0.020" SLOT	3684002
B3	BRASS VENT PLUG - 0.030" SLOT	3684003
C1	REAR DRAG INSERT BAR; ALL-STEEL	3027203
C2	REAR DRAG INSERT BAR; ANGLED-SLOT	3027202
D	FLASK PIN	3027401



Industrial
Automation
Service, Inc.

Orders and Product Info: (740)-747-2222

Hours: Mon.-Fri. 8:00 am-5:00 pm (EST). Fax orders anytime.

4590 State Route 229 West Ashley, Ohio 43003

VISUAL PARTS FINDER

BSM-2620 Squeeze Plates

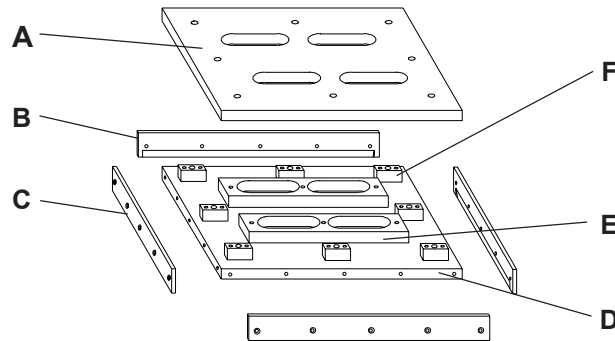

BSM-2620 Top Blow Plate Assy

Item	Description	Part No.
A	UPPER BLOW PLATE	3027204
B	BLOW PLATE WEAR STRIP - LONG (2 REQ'D)	3025004
C	BLOW PLATE WEAR STRIP - SHORT (2 REQ'D)	3025003
D	VENT PLATE	3025008
E	SLOTTED VENT SPACER BLOCK (2 REQ'D)	3025019
F	BLOW PLATE SPACER BLOCK (8 REQ'D)	3025018

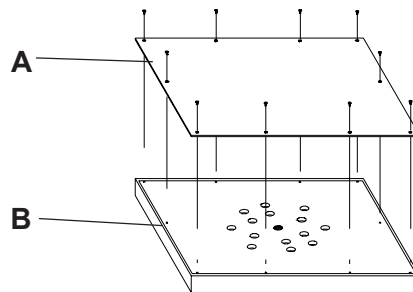

BSM-2620 Bottom Squeeze Plate

Item	Description	Part No.
A	TABLE WEAR COVER PLATE; UNMOUNTED/BLANK	3028002
B	BOTTOM SQUEEZE PLATE	3056501



**Industrial
Automation
Service, Inc.**

Orders and Product Info: (740)-747-2222

Hours: Mon.-Fri. 8:00 am-5:00 pm (EST). Fax orders anytime.

4590 State Route 229 West Ashley, Ohio 43003

FLASK BUSHINGS**BUSHING 3627403**

Description	Uses
1" I.D. x 1.5" O.D.	2016 Cope/Drag 2620 Cheek

BUSHING 3627405

Description	Uses
0.75" I.D. x 1.19" O.D.	2016 Cheek

BUSHING 3027405

Description	Uses
1.25" I.D. x 1.75" O.D.	2620 Cope/Drag

Did You Know...

Worn bushings and guide pins can lead to flask shifting during mold draw and other alignment problems. IAS bushings and guide pins are precision ground to precise tolerances. Made from hardened steel to promote durability and even wearing. Replace guide pins and bushings together for best results.

BRONZE BUSHING 3084001

Description	Uses
2" I.D. x 2.375" O.D.	2620 Cope 2016 T. Blow Cope

WIPER SEAL 3030001

Used with 3084001 Bushing

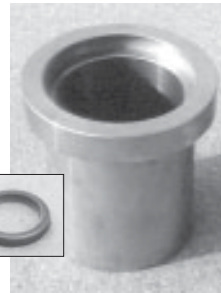
**BRONZE SLEEVE 3084002**

Description	Uses
2" I.D. x 2.375" O.D.	2620 Cope 2016 T. Blow Cope

PRESS-IN SEAL 3050001

Used with 3084002 Bushing



**Industrial
Automation
Service, Inc.**

Orders and Product Info: (740)-747-2222

Hours: Mon.-Fri. 8:00 am-5:00 pm (EST). Fax orders anytime.

4590 State Route 229 West Ashley, Ohio 43003

FLASK GUIDE PINS**GUIDE PIN 3627401**

Description	Uses
0.75" O.D. x 3.68"	2016 Cheek

**GUIDE PIN; THREADED 3627402**

Description	Uses
0.75" O.D. x 4.625"	2016 Cheek

**GUIDE PIN 3627404**

Description	Uses
1" O.D. x 4"	2016 Cheek

**GUIDE PIN; THREADED 3027404**

Description	Uses
1" O.D. x 6.5"	2620 Cheek

GUIDE PIN 3027401

Description	Uses
1.25" O.D. x 10"	2620 Cope/Drag

**GUIDE PIN 3027403**

Description	Uses
1.25" O.D. x 6"	2620 Cheek

**SHOULDER POST PIN 3627406**

Description	Uses
1/1.5" O.D. x 8"	2016 Cope/Drag

**GUIDE PIN 3027402**

Description	Uses
2" O.D. x 11"	2620 Cope

**Making it Easy...**

IAS also sells guide pins and bushings in kit form. Just tell us your machine type and the kit will include all the needed parts. Call for information and prices.



**Industrial
Automation
Service, Inc.**

Orders and Product Info: (740)-747-2222

Hours: Mon.-Fri. 8:00 am-5:00 pm (EST). Fax orders anytime.

4590 State Route 229 West Ashley, Ohio 43003

Flask Replacement Parts

ACCESSORY PARTS

CHEEK FLASK ACCESSORIES

Order core vents for cheek plates separately (see below).



BSM 2016 WEAR PLATES



BSM 2620 WEAR PLATES



2016
STRIKER
BLOCK



2620
STRIKER
BLOCK



CHEEK CENTER
PIN CARRIER

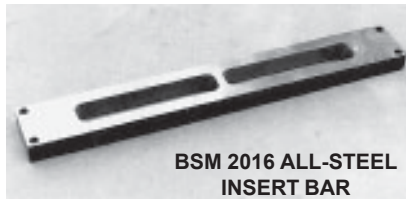

BSM 2016 ALL-STEEL
INSERT BAR



BSM 2016 ANGLED-SLOT
INSERT BAR



BRASS VENTS

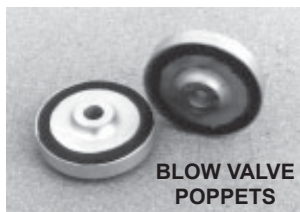

BLOW VALVE
POPPETS

Description	Part No.
BSM 2016 CHEEK WEAR PLATES; SET OF 4	3625015
BSM 2620 CHEEK WEAR PLATES; SET OF 4	3025020
CENTER PIN CARRIER (BSM 2016)	3225002
CENTER PIN CARRIER; THREADED (BSM 2016)	3225003
CHEEK TRANSFER GUIDE TRACK (BSM 2016)	3225000
CHEEK TRANSFER GUIDE TRACK (BSM 2620)	3325002
CHEEK CARRIAGE V-WHEEL	3224301
CHEEK CARRIAGE WHEEL BEARING	3224303
BSM 2016 CHEEK STRIKER BLOCK	3225008
BSM 2620 CHEEK STRIKER BLOCK	3325001
BUSHING PROTECTOR CAPS; URETHANE	3636011

DRAG INSERT BARS

Offered in two styles. All-steel version has straight through slots. Angled-slot bar deflects the sand flow downward, protecting deep patterns and promoting better mold filling.

Description	Part No.
BSM 2016 All-Steel Insert Bar (OEM design)	3625001
BSM 2016 Angled-Slot Insert Bar	3625009
BSM 2620 All-Steel Insert Bar (OEM design)	3027203
BSM 2620 Angled-Slot Insert Bar	3027202

FLASK CORE VENT PLUGS

Description	Part No.
BRASS VENT PLUG; 0.014" SLOT GAP	3684001
BRASS VENT PLUG; 0.020" SLOT GAP	3684002
BRASS VENT PLUG; 0.030" SLOT GAP	3684003

BLOW VALVE POPPETS

A low-cost, high-wear item; good to keep in stock! OEM design. Made of aluminum with elastomer sealing ring.

Description	Part No.
Blow Valve Poppet	3266410



Industrial
Automation
Service, Inc.

Orders and Product Info: (740)-747-2222

Hours: Mon.-Fri. 8:00 am-5:00 pm (EST). Fax orders anytime.

4590 State Route 229 West Ashley, Ohio 43003

Sand Magazine Replacement Parts

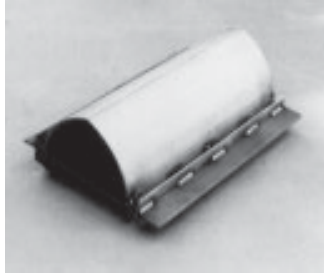

SAND BAFFLE

STAINLESS STEEL SAND BAFFLES

Made of heavy gauge stainless steel to precise OEM specifications. Used on BSM 2016 machines only.

Description	Part No.
SAND BAFFLE ASSY	3228001



AIR AGITATOR NOZZLE

AIR AGITATOR NOZZLE

12 inch height. Made with dual stainless steel fine mesh screens internally. A large hex nut welded to the end and stainless steel threads makes installation and removal easier.

Description	Part No.
AIR AGITATOR NOZZLE ASSY; 12"	3228005

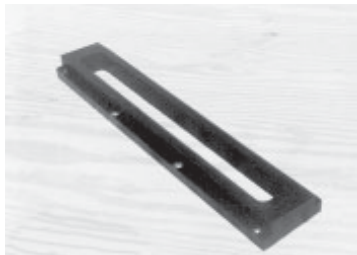

COPE BLOW SLOT SEAL

COPE BLOW SLOT SEAL

OEM design. Constructed of durable polyurethane and steel. Used on BSM 2016 machines only.

Description	Part No.
COPE BLOW SLOT SEAL	3258601

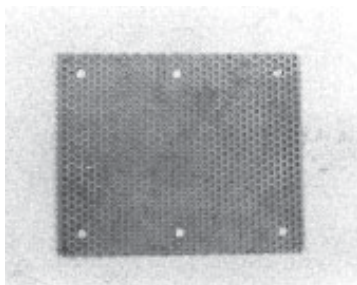

SAND SCREENS SUPPORT PLATES

SAND MAGAZINE DOORS and SCREENS

Screens are made of fine mesh stainless steel and are cut to size for the door application. The support plate is used in the 11" x 16" magazine door and is pre-drilled for the door bolt pattern.

Description	Part No.
SAND SCREEN SUPPORT PLATE; 11" X 16"	3228004
SAND MAGAZINE DOOR SCREEN; 11" X 16"	3288001
SAND MAGAZINE DOOR SCREEN; 8" X 15"	3288002



Industrial
Automation
Service, Inc.

Orders and Product Info: (740)-747-2222

Hours: Mon.-Fri. 8:00 am-5:00 pm (EST). Fax orders anytime.

4590 State Route 229 West Ashley, Ohio 43003

DRAG BLOW SLOT SEALS

AIR-CURTAIN STYLE
DRAG BLOW SEAL

**AIR-CURTAIN DRAG BLOW SLOT SEALS**

No moving parts. A high pressure curtain of air contains the incoming sand stream during the blowing operation. The air-curtain seal is less prone to failure due to punctures.

Description	Part No.
BSM 2016 AIR-CURTAIN DRAG BLOW SEAL	3258603
BSM 2620 AIR-CURTAIN DRAG BLOW SEAL	3338602



Industrial
Automation
Service, Inc.

Orders and Product Info: (740)-747-2222

Hours: Mon.-Fri. 8:00 am-5:00 pm (EST). Fax orders anytime.

4590 State Route 229 West Ashley, Ohio 43003

Sand Magazine Replacement Parts



MODULAR DRAG BLOW SLOT SEALS

Are you tired of replacing your entire blow slot seal just because of a tiny rip? This revolutionary new blow seal is designed to last longer and be less expensive to maintain than other seals. The critical inflating ring is shielded from tramp metals by the steel retaining bars. Only the inflating ring is replaced when damaged and it costs much less than an entire blow seal. Replacement retaining bar sets come with all required fasteners.

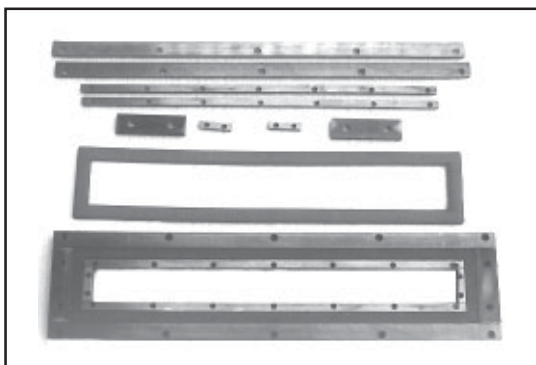
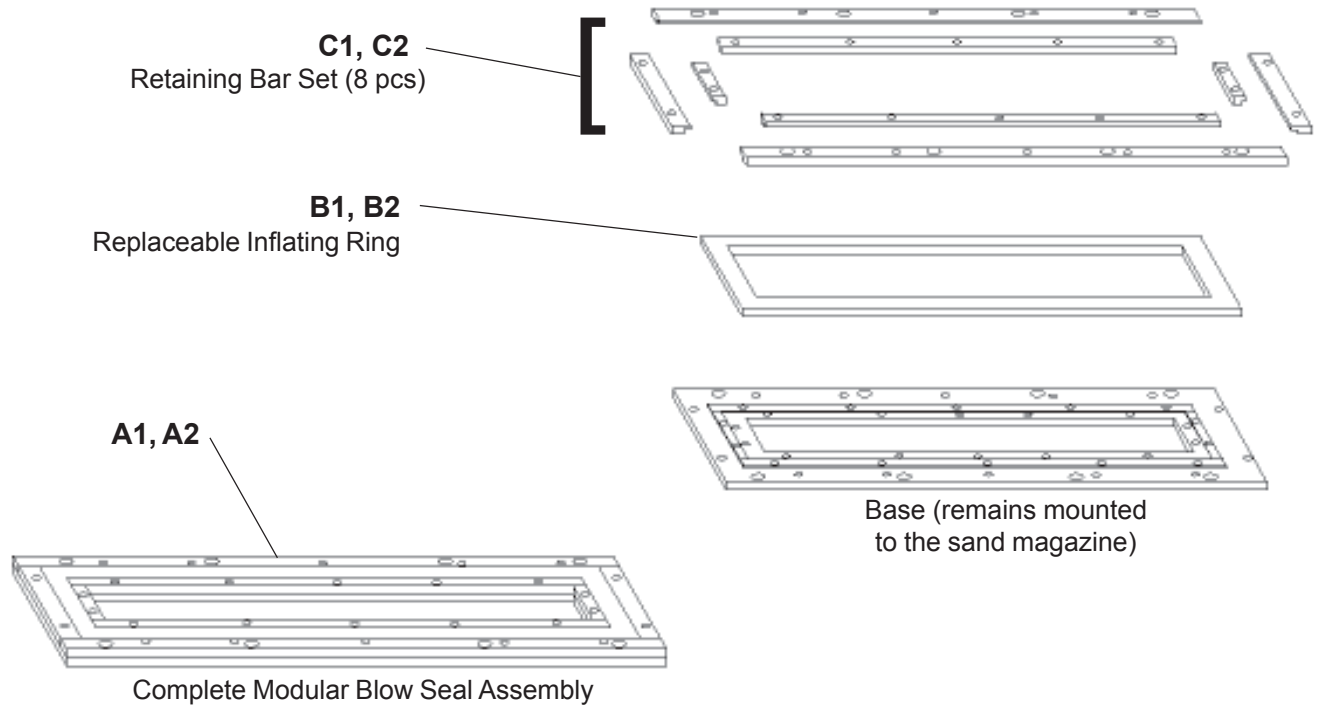

Item	Description	Part No.
A1	2016 MOD BLOW SEAL ASSY	3225011
A2	2620 MOD BLOW SEAL ASSY	3325004
B1	REPLACEMENT RING; 2016	3236001
B2	REPLACEMENT RING; 2620	3336001
C1	RET. BAR SET; BSM 2016	3225010
C3	RET. BAR SET; BSM 2620	3325003



**Industrial
Automation
Service, Inc.**

Orders and Product Info: (740)-747-2222

Hours: Mon.-Fri. 8:00 am-5:00 pm (EST). Fax orders anytime.

4590 State Route 229 West Ashley, Ohio 43003

Sand Gate Replacement Parts

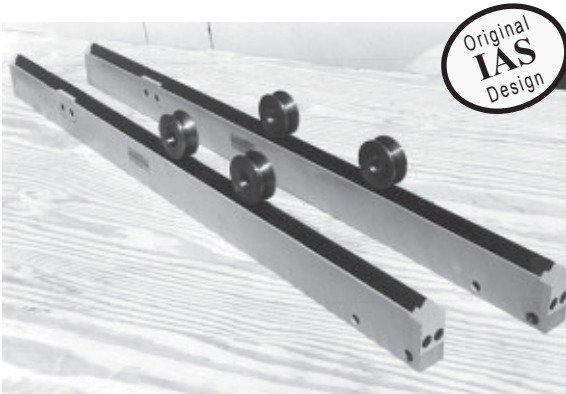

COMPLETE SANDGATE TRACK ASSEMBLY
SHOWN WITH V-GROOVE CARRIAGE WHEELS

SAND GATE TRACKS AND CARRIAGE WHEELS

Description	Part No.
COMPLETE SAND GATE TRACK ASSY	3225009

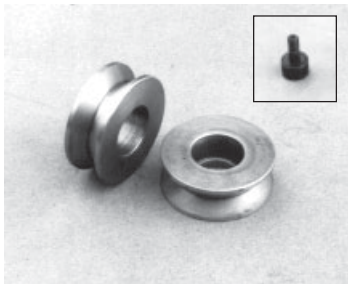

SAND GATE V-GROOVE CARRIAGE
WHEEL AND BEARING (INSET)

SAND GATE CARRIAGE WHEELS and BEARINGS

Made of hardened steel. Precision ground inner bearing races.

Description	Part No.
SAND GATE V-GROOVE CARRIAGE WHEEL	3224302
SAND GATE CARRIAGE WHEEL BEARING	3220012

SAND GATE SHUTOFF SEALS and DIAPHRAGMS

Worn sand gate shutoff seals are a major cause of soft or incomplete molds. These seals are precision molded from tough, wear-resistant polyurethane for long life.



SAND GATE SHUTOFF SEAL
(ROUND STYLE)

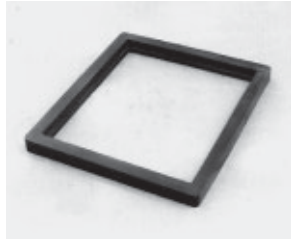

SAND GATE SHUTOFF SEAL
(RECTANGULAR STYLE)

Description	Part No.
SAND GATE SHUTOFF SEAL; ROUND	3236009
SAND GATE SHUTOFF SEAL; RECTANGULAR	3236010
SAND GATE DIAPHRAGM; 20" Dia. (for Round Seal)	3280002
SAND GATE DIAPHRAGM; 23" Dia. (for Rect. Seal)	3280003



Industrial
Automation
Service, Inc.

Orders and Product Info: (740)-747-2222

Hours: Mon.-Fri. 8:00 am-5:00 pm (EST). Fax orders anytime.

4590 State Route 229 West Ashley, Ohio 43003

FLASK REBUILDING

IAS became the first independent rebuilder of Beardsley & Piper automatic molding equipment in 1975. Since then, steady innovation and consistent quality has made us the rebuilder of choice among foundries across North America. Through this experience, **IAS** has learned the traditional flask problem areas and what rebuild methods insure the maximum service life.

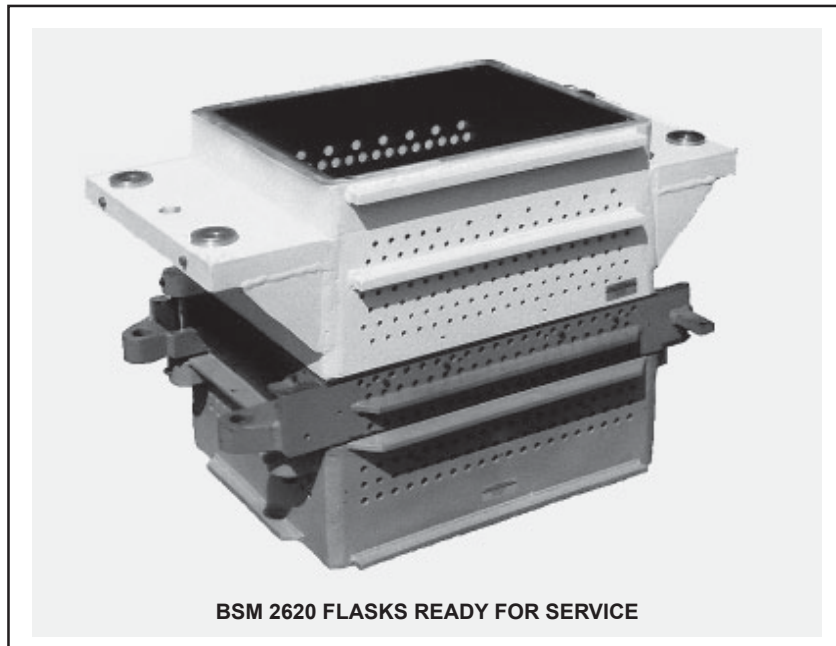

**Industrial
Automation
Service, Inc.**

Orders and Product Info: (740)-747-2222

Hours: Mon.-Fri. 8:00 am-5:00 pm (EST). Fax orders anytime.

4590 State Route 229 West Ashley, Ohio 43003

Flask Rebuilding Services

The IAS Flask Rebuild...What To Look For

Proper Flask Heights: All mating surfaces are machined and made parallel. Additional metal stock is added to restore proper dimensional height where required.

Durable Liners: All interior surfaces are specially blasted and prepared for better elastomer bonding.

Cheek Flask Details: Cheek flasks come with new steel wear plates with brass vent plugs pre-installed. The pattern mounting holes are restored to like-new condition.

Finishing Touches: All flasks are returned with their required bushings, guide pins, and locking hardware. (Note: The 2620 cope is not supplied with the 2" guide pins or bronze bushings since many foundries chose to reuse these items.)

New or Used...IAS Can Provide You With Spare Flasks

Many foundries choose to carry at least one complete set of spare flasks. Having a spare set gives you extra rebuilding flexibility and provides security in the event of premature flask failure or an unexpected machine wreck. **IAS** has a limited number of used flasks in stock for resale. They can be purchased remanufactured or as-is. **IAS** can also provide **NEW** flasks at very competitive prices. Call for prices and availability.

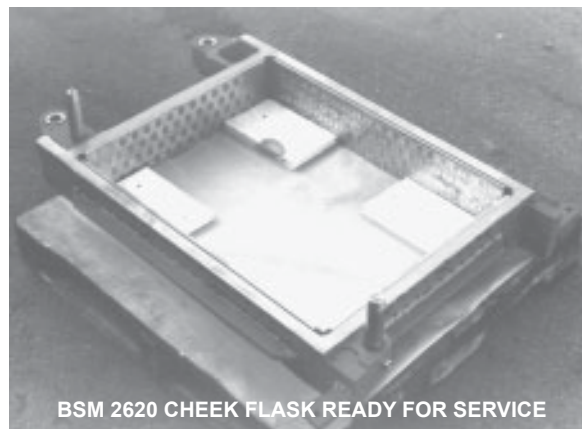

**Industrial
Automation
Service, Inc.**

Orders and Product Info: (740)-747-2222

Hours: Mon.-Fri. 8:00 am-5:00 pm (EST). Fax orders anytime.

4590 State Route 229 West Ashley, Ohio 43003

Flask Remanufacturing Price Codes(See *Rebuilding Services* in Price List)**BSM 2016 Blowmatic Flasks**

Description	Price Code
BSM 2016 Cope	2016COPE
BSM 2016 Cheek	2016CHEEK
BSM 2016 Drag	2016DRAG
BSM 2016 Bottom Squeeze Plate	2016BPLT
BSM 2016 Bottom Sqz Plate with Mounted Cover Plate	2016BPLT w/C
BSM 2016 Top Squeeze Plate	2016TPLT

BSM 2620 Blowmatic Flasks

Description	Price Code
BSM 2620 Cope	2620COPE
BSM 2620 Cheek	2620CHEEK
BSM 2620 Drag	2620DRAG
BSM 2620 Bottom Squeeze Plate	2620BPLT
BSM 2620 Bottom Sqz Plate with Mounted Cover Plate	2620BPLT w/C



**Industrial
Automation
Service, Inc.**

Orders and Product Info: (740)-747-2222

Hours: Mon.-Fri. 8:00 am-5:00 pm (EST). Fax orders anytime.

4590 State Route 229 West Ashley, Ohio 43003

Clamp Assembly Rebuilding

What is a hydraulic rebuild at IAS?

IAS understands the brutal environment that the clamp assembly must operate in. Therefore, we have developed a systematic approach to the remanufacturing process. All of our rebuilds include the following:

- * Replacement of all steel rings, U-cup seals, wiper seals, and O-rings with original equipment components.
- * Both the drag control and squeeze pistons are brought back to original size and chrome plating specification. Piston surfaces are polished after re-plating to minimize break-in times and promote long life.
- * Reassembled in a clean environment by technicians who specialize in B&P hydraulics *only*.

Stop Hydraulic Leaks... Stop Wasting Money

IAS offers a variety of methods for rebuilding your clamp assembly. The option you choose will depend on your downtime allowance and if you have a spare clamp assembly.

REBUILD OPTION 1: Complete Rebuild of Your Unit by IAS

If you have an upcoming planned plant shutdown or have a spare clamp assembly, you can have IAS perform the rebuild in our shop.

Clamp Assembly Exchange Program

IAS keeps a limited number of spare clamp assemblies in stock to be used as exchange units. This can turn your task into a weekend swap job, instead of extended downtime if you do not have a spare clamp assembly. Please call ahead, as our exchange unit availability does vary.



INSPECTION OF A 2016 DRAG CONTROL PISTON AFTER FINAL O.D. POLISHING

Clamp Assembly Rebuild Price Codes

(See *Rebuilding Services* in the Price List)

Description	Price Code
BSM 2016 CLAMP ASSEMBLY REBUILD	2016CLMP
BSM 2620 CLAMP ASSEMBLY REBUILD	2620CLMP



Industrial
Automation
Service, Inc.

Orders and Product Info: (740)-747-2222

Hours: Mon.-Fri. 8:00 am-5:00 pm (EST). Fax orders anytime.

4590 State Route 229 West Ashley, Ohio 43003

Clamp Assembly Rebuilding

REBUILD OPTION 2: Rebuild In Your Foundry

For maintenance departments that have the resources to rebuild the clamp assembly in-house, **IAS** can provide all needed rebuild components in convenient kit form. All components are to OEM specification and quality. If you have never rebuilt your clamp assembly before, an **IAS** rebuild kit can provide you the assurance in knowing that all of the needed components are in one box.

Spare Piston Sets

Reconditioning the pistons in the clamp assembly is required in most instances to guarantee a high performance rebuild. Unfortunately, reconditioning hydraulic pistons can take up to 6 weeks and for most foundries that much downtime is just not feasible. **IAS** has a solution; keep a spare set of pistons for weekend rebuilds. We have provided many foundries with **BRAND NEW** piston sets for a fraction of the cost of an entire spare clamp assembly.

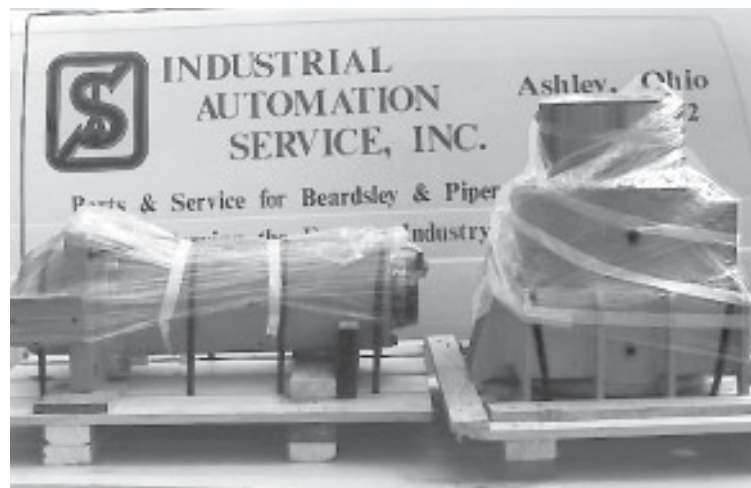

REBUILT BSM 2620 CLAMP ASSEMBLY READY FOR SHIPMENT



**Industrial
Automation
Service, Inc.**

Orders and Product Info: (740)-747-2222

Hours: Mon.-Fri. 8:00 am-5:00 pm (EST). Fax orders anytime.

4590 State Route 229 West Ashley, Ohio 43003

Clamp Assembly Parts



BSM 2016 BRONZE RETAINING BUSHING WITH E-Z WIPER INSTALL DESIGN



SQUEEZE PISTON WIPER SEAL

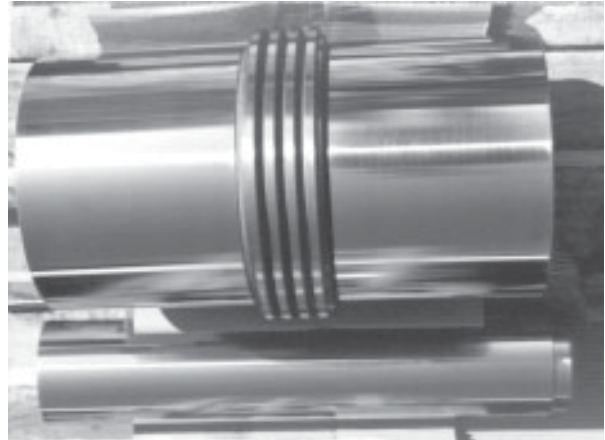

NEWLY MANUFACTURED DRAG CONTROL (TOP) AND SQUEEZE (BOTTOM) PISTONS



NEW BSM 2016 DRAG CONTROL PISTON



CAST STEEL PISTON RING FOR DRAG CONTROL CYLINDER

BSM 2016 Clamp Assembly Components

Item	Description	Qty Req'd	Part No.
A	U-CUP SEAL-SQUEEZE PISTON	1	3236002
B	WIPER SEAL-SQUEEZE PISTON	1	3236003
C	U-CUP SEAL-DRAG CONTROL PISTON	2	3236004
D	WIPER SEAL-DRAG CONTROL PISTON	2	3236005
E	O-RING (for Bronze Retaining Bushing)	2	3236006
F	O-RING (for Squeeze Piston Base)	1	3236007
G	STEEL PISTON RING	3	3247000
	COMPLETE REBUILD KIT (All of the above)	1	3280001
	Additional Clamp Assembly Items		
	NEW DRAG CONTROL PISTON	1	3224102
	NEW SQUEEZE PISTON	1	3224101
	BRONZE RETAINING BUSHING (w/E-Z Wiper Install Design)	2	3284001
	DRAG CONTROL WIPER RETAINING RING (12 HOLE) 2		3222403
	DRAG CONTROL WIPER RETAINING RING (24 HOLE) 2		3222401



Industrial Automation Service, Inc.

Orders and Product Info: (740)-747-2222

Hours: Mon.-Fri. 8:00 am-5:00 pm (EST). Fax orders anytime.

4590 State Route 229 West Ashley, Ohio 43003

Clamp Assembly Parts

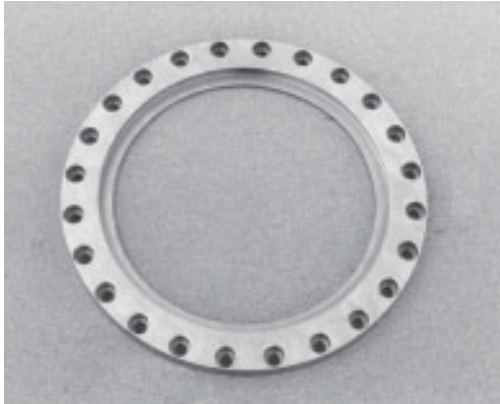

WIPER RETAINING RING FOR THE
DRAG CONTROL PISTON

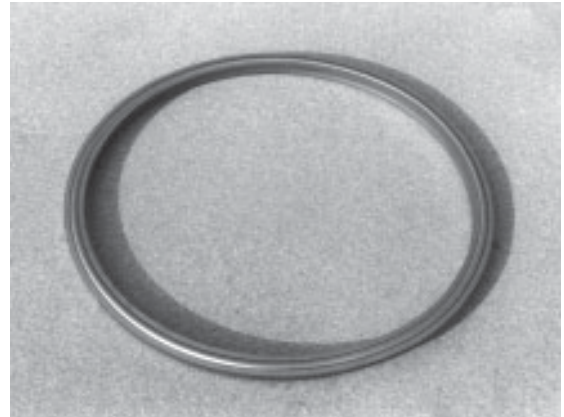

DRAG CONTROL WIPER SEAL

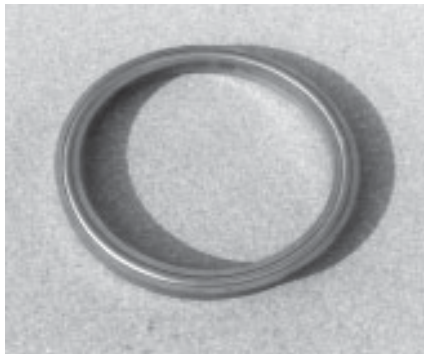

SQUEEZE PISTON WIPER SEAL



BSM 2620 BRONZE RETAINING BUSHING
WITH E-Z WIPER INSTALL DESIGN

BSM 2620 Clamp Assembly Components

Item	Description	Qty Req'd	Part No.
A	U-CUP SEAL-SQUEEZE PISTON	1	3336002
B	WIPER SEAL-SQUEEZE PISTON	1	3336003
C	U-CUP SEAL-DRAG CONTROL PISTON	4	3336004
E	O-RING (for Bronze Retaining Bushing)	2	3336006
F	O-RING (for Squeeze Piston Base)	1	3336005
G	STEEL PISTON RING	3	3347000
	COMPLETE REBUILD KIT (All of the above)	1	3380001
	Additional Clamp Assembly Items		
	NEW DRAG CONTROL PISTON (Not Shown)	1	3324102
	NEW SQUEEZE PISTON (Not Shown)	1	3324101
	BRONZE RETAINING BUSHING (w/E-Z Wiper Install Design)	2	3384001



Industrial
Automation
Service, Inc.

Orders and Product Info: (740)-747-2222

Hours: Mon.-Fri. 8:00 am-5:00 pm (EST). Fax orders anytime.

4590 State Route 229 West Ashley, Ohio 43003